



Digital Scroll compressors for Refrigeration

ZBD30KC* & ZBD45KC*
ZFD18KVE

Application Guidelines

1	Safety instructions	1
1.1	Icon explanation	1
1.2	Safety statements	1
1.3	General instructions	2
2	Product description	2
2.1	Common information about Copeland Scroll™ compressors.....	2
2.2	About this guideline.....	2
2.3	Nomenclature.....	3
2.4	Application range	3
2.4.1	<i>Qualified refrigerants and oils</i>	3
2.4.2	<i>Application limits</i>	3
2.5	Compressor dimensions	4
2.6	Copeland Digital Scroll™ - operation, design and performance.....	4
3	Installation	5
3.1	Compressor handling.....	5
3.1.1	<i>Transport and storage</i>	5
3.1.2	<i>Positioning and securing</i>	5
3.1.3	<i>Installation location</i>	5
3.1.4	<i>Mounting parts</i>	5
3.2	Brazing procedure.....	6
3.3	Shut-off valves and adaptors	7
3.4	Solenoid valves for models ZBD30KCE, ZBD45KCE and ZFD18KVE	7
3.5	Solenoid valve installation.....	8
3.5.1	<i>General</i>	8
3.5.2	<i>Tubing recommendations:</i>	8
3.6	ZFD18KVE Copeland Scroll™ compressor with vapour injection	10
3.7	Compressors in parallel	10
3.8	Discharge check valve	11
3.9	Oil separator	11
3.10	Accumulators	11
3.11	Screens	12
3.12	Mufflers	12
3.13	Reversing valves.....	12
3.14	Suction line noise and vibration	12
4	Electrical connection	14
4.1	General recommendations.....	14
4.2	Electrical installation	14
4.2.1	<i>Terminal box</i>	14
4.2.2	<i>Motor winding</i>	14
4.2.3	<i>Protection devices</i>	14



4.2.4	Crankcase heaters	14
4.3	Pressure control	15
4.3.1	High-pressure control	15
4.3.2	Low-pressure control	15
4.3.3	IPR valve (Internal Pressure Relief valve)	15
4.4	Discharge temperature protection	15
4.5	High-potential testing	16
5	Starting up & operation.....	17
5.1	Strength pressure test.....	17
5.2	Tightness/pressure test.....	17
5.3	Preliminary checks – Pre-starting	17
5.4	Pressure fluctuations	17
5.5	Charging procedure	18
5.6	Rotation direction	18
5.7	Starting	18
5.8	Deep vacuum operation.....	18
5.9	Shell temperature.....	19
5.10	Minimum run time	19
5.11	Power factor	19
6	Maintenance & repair	19
6.1	Exchanging the refrigerant.....	19
6.2	Rotalock valves	19
6.3	Replacing a compressor	19
6.3.1	Compressor replacement.....	20
6.3.2	Start-up of a new or replacement compressor	20
6.4	Lubrication and oil removal	20
6.5	Unbrazing system components	21
6.6	Copeland Scroll™ functional check	21
7	Dismantling & disposal.....	21







1 Safety instructions

These compressors are constructed according to the latest European and US Safety Standards. Particular emphasis has been placed on the user's safety. Certain residual hazards from the compressor are not avoidable. These compressors are intended for installation in systems according to the EC Machines directive. They may be put to service only if they have been installed in these systems according to instructions and conform to the corresponding provisions of legislation. For relevant standards please refer to Manufacturers Declaration, available on request.

These instructions should be retained throughout the lifetime of the compressor.

You are strongly advised to follow these safety instructions.

1.1 Icon explanation

 <p>WARNING This icon indicates instructions to avoid personal injury and material damage.</p>	 <p>CAUTION This icon indicates instructions to avoid property damage and possible personal injury.</p>
 <p>High Voltage This icon indicates operations with a danger of electric shock.</p>	 <p>IMPORTANT This icon indicates instructions to avoid malfunction of the compressor.</p>
 <p>Danger of burning or frostbite This icon indicates operations with a danger of burning or frostbite.</p>	<p>NOTE This word indicates a recommendation for easier operation.</p>
 <p>Explosion Hazard This icon indicates operations with a danger of explosion.</p>	

1.2 Safety statements

- Refrigerant compressors must be employed only for their intended use.
- Only qualified and authorized HVAC or refrigeration personnel are permitted to install, commission and maintain this equipment.
- Electrical connections must be made by qualified electrical personnel.
- All valid standards for connecting electrical and refrigeration equipment must be observed.



Use personal safety equipment. Safety goggles, gloves, protective clothing, safety boots and hard hats should be worn where necessary.

1.3 General instructions



WARNING

System breakdown! Personal injuries! Never install a system in the field and leave it unattended when it has no charge, a holding charge, or with the service valves closed without electrically locking out the system.

System breakdown! Personal injuries! Only approved refrigerant and refrigeration oils must be used.



High shell temperature! Burning! Do not touch the compressor until it has cooled down. Ensure that other materials in the area of the compressor do not get in touch with it. Lock and mark accessible sections.



CAUTION

Overheating! Bearing damage! Do not operate compressors without refrigerant charge or without being connected to the system.



IMPORTANT

Transit damage! Compressor malfunction! Use original packaging. Avoid collisions and tilting.

2 Product description

2.1 Common information about Copeland Scroll™ compressors

The Copeland Scroll™ compressor has been under development at Copeland since 1979. It is the most efficient and durable compressor Copeland has ever developed for air conditioning and refrigeration.

This application guideline deals with Copeland Digital Scroll™ compressors for refrigeration ZBD30KC*, ZBD45KC* and ZFD18KVE. These compressors include a wide range of capacities, electrical options, and features.

2.2 About this guideline

This guideline is intended to enable users to ensure the safe installation, starting, operation and maintenance of Copeland Scroll™ compressors.

This guideline is not intended to replace the system expertise available from system manufacturers.

2.3 Nomenclature

The model designation contains the following technical information about the compressor:

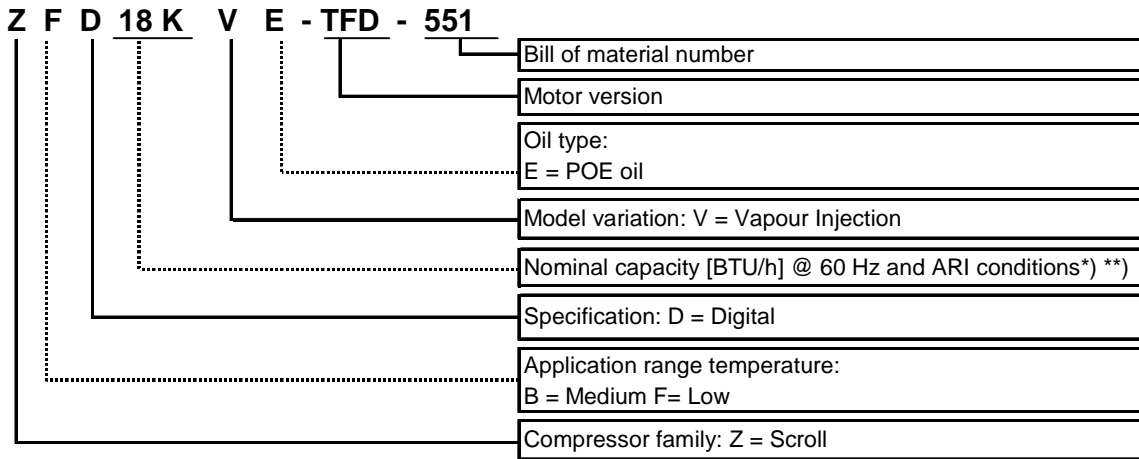

C_T_ZRD_019

*ARI-Conditions for medium temperature:

Evaporating temperature	-6.7°C	Liquid sub-cooling	0 K
Condensing temperature	48.9°C	Ambient temperature	35°C
Suction return gas temperature	18.3 K		

**ARI-Conditions for low temperature:

Evaporating temperature	-31.67°C	Liquid sub-cooling	0 K
Condensing temperature	40.56°C	Ambient temperature	35°C
Suction return gas temperature	18.33 K		

2.4 Application range

2.4.1 Qualified refrigerants and oils

	ZBD30/45KCE	ZFD 18 KVE
Qualified Refrigerant	R404A, R507 and R22	R404A, R507
Copeland Standard Oil	ICI Emkarate RL 32 - 3MAF	
Servicing Oil	ICI Emkarate RL 32 - 3MAF, MOBIL EAL Arctic 22 CC	

Table 1

Oil recharge values can be taken from Copeland brochures or Copeland Selection Software.

2.4.2 Application limits

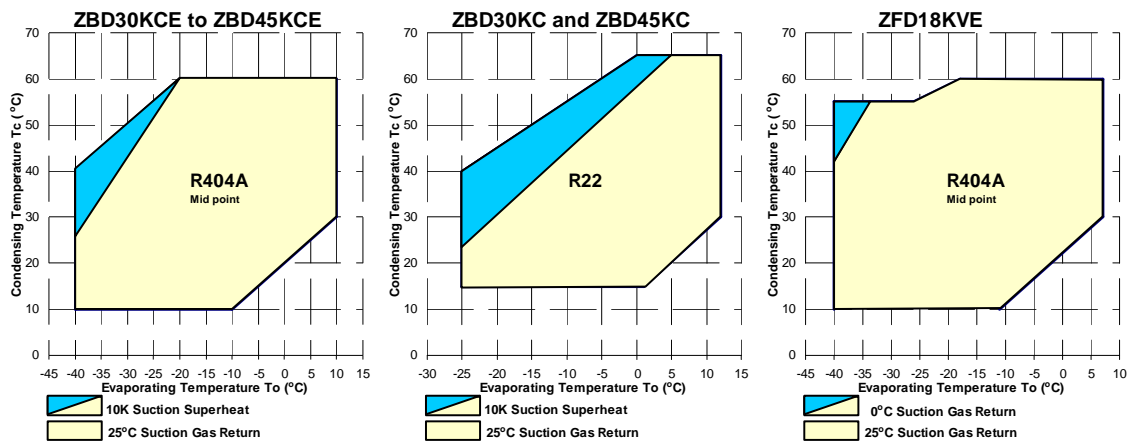

Figure 1: Application envelope

2.5 Compressor dimensions

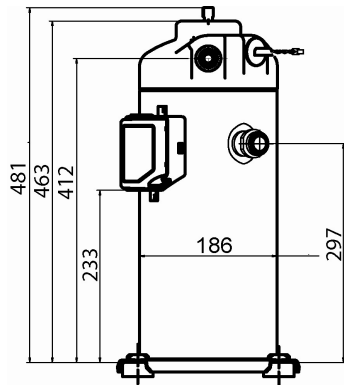

Figure 2: Dimensions of ZBD30KCE, ZBD45KCE and ZFD18KVE

2.6 Copeland Digital Scroll™ - operation, design and performance

The Copeland Digital Scroll™ is a compressor capable of seamlessly modulating capacity from 10% to 100%.

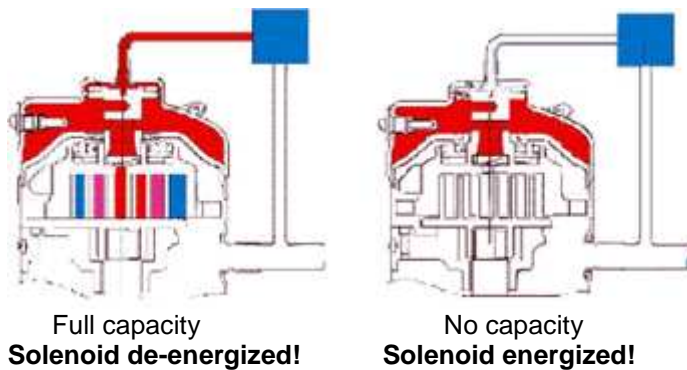

Figure 3 : Modulation of Scroll models ZBD30KCE, ZBD45KCE and ZFD18KVE

The external solenoid valve is an accessory and is not supplied with the compressor. This “normally closed” (de-energized) solenoid valve is a key component for achieving modulation. When the solenoid valve is in its normally closed position, the compressor operates at full capacity or in the “loaded state”. When the solenoid valve is energized, the two scroll elements move apart axially, or into the “unloaded state”. During the unloaded state, the compressor motor continues running, but since the scrolls are separated, there is no compression. During the “loaded state”, the compressor delivers 100% capacity and during the “unloaded state”, the compressor delivers 0% capacity. A cycle consists of “loaded state” and “unloaded state”. By varying the time of “loaded state” and “unloaded state”, an average capacity is obtained.

Example: In a 20-second cycle, the average capacity is 75% if the “loaded time” is 15 seconds and the “unloaded time” is 5 seconds.

3 Installation



WARNING

High pressure! Injury to skin and eyes possible! Be careful when opening connections on a pressurized item.

3.1 Compressor handling

3.1.1 Transport and storage



WARNING

Risk of collapse! Personal injuries! Move compressors only with appropriate mechanical or handling equipment according to weight. Keep in the upright position. Stack pallets on top of each other when not exceeding 300 kg. Do not stack single boxes on top of each other. Keep the packaging dry at all times.

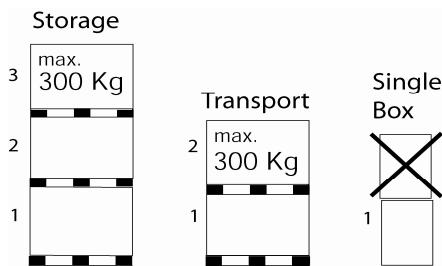

Figure 4

3.1.2 Positioning and securing



IMPORTANT

Handling damage! Compressor malfunction! Only use the lifting eyes whenever the compressor requires positioning. If the compressor has two lifting tabs, both must be used for lifting. Using discharge or suction connections for lifting may cause damage or leaks.

If possible, the compressor should be kept vertical during handling. The discharge connection plug should be removed first before pulling the suction connection plug to allow the dry air pressure inside the compressor to escape. Pulling the plugs in this sequence prevents oil mist from coating the suction tube making brazing difficult. The copper coated steel suction tube should be cleaned before brazing.

3.1.3 Installation location

Ensure the compressors are installed on a solid level base.

3.1.4 Mounting parts

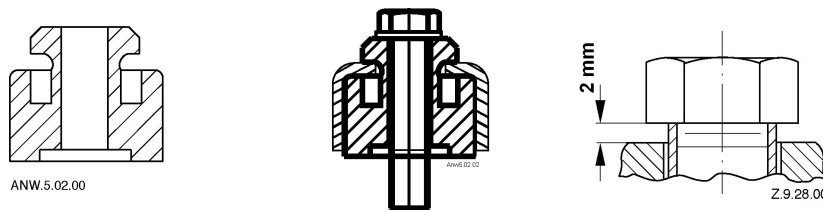

Figure 5

Four vibration absorber grommets are supplied with each compressor. They dampen the start-up surge of the compressor and minimise sound and vibration transmission to the compressor base during operation. The metal sleeve inside is a guide designed to hold the grommet in place. It is not designed as a load-bearing member, and application of excessive torque to the bolts can crush the sleeve. Its inner diameter is approximately 8.5 mm to fit, eg, an M8 screw. The mounting torque should be 13 ± 1 Nm. It is critically important that the grommet is not

compressed. A clearance space of approximately 2 mm between the bottom of the washer and the top of the grommet spacer is recommended (see **Fig. 5**).

If the compressors are mounted in tandem or used in parallel, then the hard mountings (bolt M 9 5/16") are recommended. The mounting torque should be 27 ± 1 Nm. It is possible to deliver these hard mounting parts as a kit, or on request to deliver the compressor with these parts instead of the rubber grommets.

3.2 Brazing procedure

IMPORTANT



Blockage! Compressor breakdown! Maintain a flow of oxygen-free nitrogen through the system at very low pressure during brazing. Nitrogen displaces the air and prevents the formation of copper oxides in the system. If allowed to form, the copper oxide material can later be swept through the system and block screens such as those protecting capillary tubes, thermal expansion valves, and accumulator oil return holes.

Contamination or moisture! Bearing failure! Do not remove the plugs until the compressor is set into the unit. This minimises any entry of contaminants and moisture.

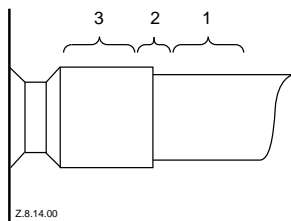

Figure 6: Suction Tube Brazing

Copeland Scroll™ compressors have copper-plated steel suction- and discharge tubes. These tubes are far more robust and less prone to leaks than copper tubes. Due to the different thermal properties of steel and copper, brazing procedures may have to be changed from those commonly used.

Figure 6 shows the proper procedures for brazing the suction and discharge lines to a scroll compressor.

To connect:

- The copper-coated steel tubes on scroll compressors can be brazed in approximately the same manner as any copper tube.
Recommended brazing materials: any silfos material is recommended, preferably with a minimum of 5% silver. However, 0% silver is acceptable.
- Be sure tube fitting inner diameter and tube outer diameter are clean prior to assembly.
- Using a double-tipped torch, apply heat in area 1.
- As the tube approaches brazing temperature, move the torch flame to area 2.
- Heat area 2 until braze temperature is attained, moving the torch up and down and rotating around the tube as necessary to heat the tube evenly. Add braze material to the joint while moving the torch around the joint to flow braze material around the circumference.
- After the braze material flows around the joint, move the torch to heat area 3. This will draw the braze material down into the joint. The time spent heating area 3 should be minimal.
- As with any brazed joint, overheating may be detrimental to the final result.

To disconnect:

- Heat joint areas 2 and 3 slowly and uniformly until the braze material softens and the tube can be pulled out of the fitting.

To reconnect:

- Recommended brazing materials: Silfos with minimum 5% silver or silver braze used on other compressors. Due to the different thermal properties of steel and copper, brazing procedures may have to be changed from those commonly used.

3.3 Shut-off valves and adaptors



CAUTION

Leaking system! System breakdown! It is strongly recommended to periodically re-torque all pipe and fixing connections to the original setting after the system has been put into operation.

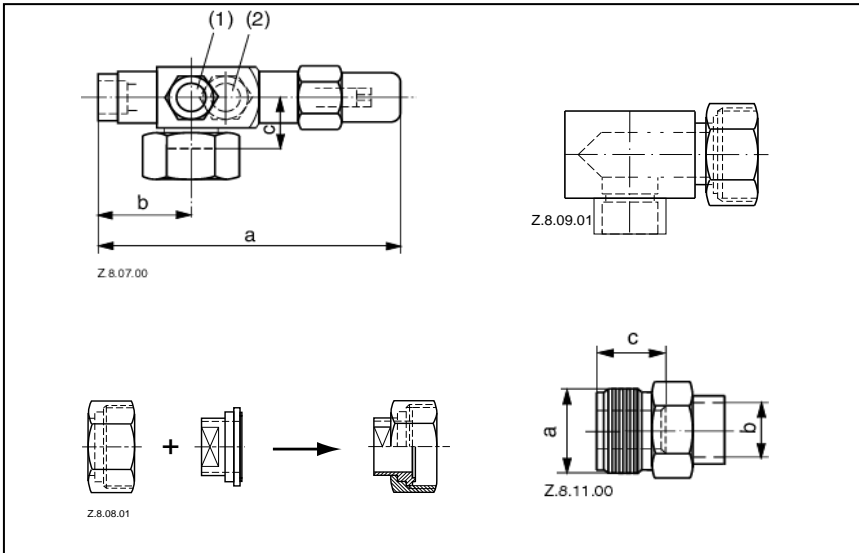

Copeland Scroll™ compressors are delivered with a discharge check valve fitted inside the discharge port and rubber plugs fitted to the suction and discharge port as standard. There are options to fit either Rotalock valves, or Rotalock adaptors or just make brazing connections.

Braze connections can be converted to Rotalock by means of adaptors. Rotalock shut-off valves are available for the suction as well as discharge side. Using either straight or angled adaptors provides a way to convert a Rotalock into a brazing connection.

Refer to the following table for proper tightening torques:

	Torque [Nm]
Rotalock 1"-14UNS	70-80
Rotalock 1"1/4-12UNF	110-135

C_T_SCA_002

Note: More information concerning adaptors and shut-off valves can be found in the "Spare parts list".

Table 2

3.4 Solenoid valves for models ZBD30KCE, ZBD45KCE and ZFD18KVE



IMPORTANT

The external solenoid valve is a critical component for proper function of this compressor. **Only** the Copeland solenoid valve supplied as a requested accessory must be used.

Care must be taken during the brazing process that no solid parts can enter the control piston compartment or the solenoid valve tubing. To prevent solid parts from entering the control valve seat, the solenoid valve kit contains a filter screen, which has to be placed into the horizontal tube of the valve before brazing the tube connections as shown in the figures below (figures 7 & 8).

The solenoid valve has to be fitted in such a way that the sleeve with the stem inside – which supports the solenoid coil – is fixed and aligned in an upright position.

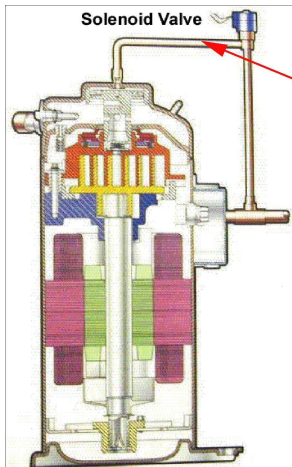

Figure 7: Position of the external solenoid valve

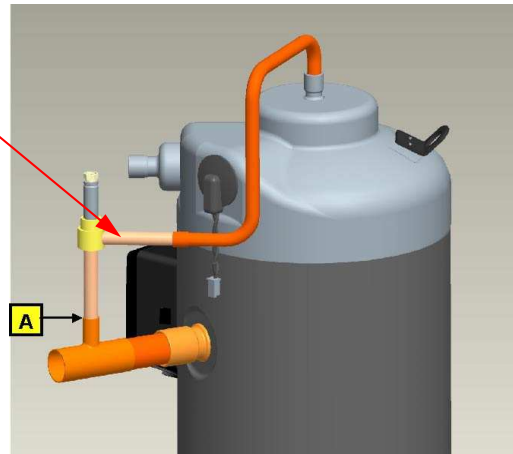

Figure 8: Copeland recommended piping



Figure 9: Optional Rotalock connection

3.5 Solenoid valve installation

3.5.1 General

The solenoid valve must be mounted vertically, to within $\pm 15^\circ$. Horizontal mounting is not permitted.

The valve operation is directional. See diagram below for inlet and outlet locations.

3.5.2 Tubing recommendations:

The tube from the solenoid to the suction, marked "A" (see **Fig. 8**), should be as short as possible ($< 7,5$ cm.). Dimensions for a typical tube going from the top of the compressor are shown in **figures 10 & 11**.

Do not restrict the line size coming from or leaving the solenoid valve. Use 3/8" soft drawn copper.

IMPORTANT

This tube has been tested and qualified at 50 and 60 Hz operation for running stresses and resonance in a single compressor lab environment. However, in some compressor applications such as racks and transport applications, the OEM is strongly advised to re-confirm the acceptability of the tube when the compressor is subject to additional vibration inputs.

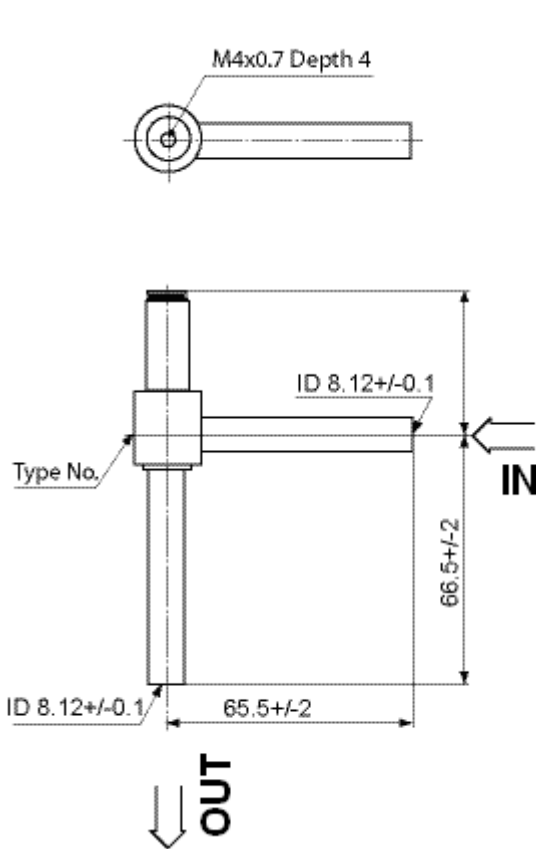

Figure 10: Control valve without coil

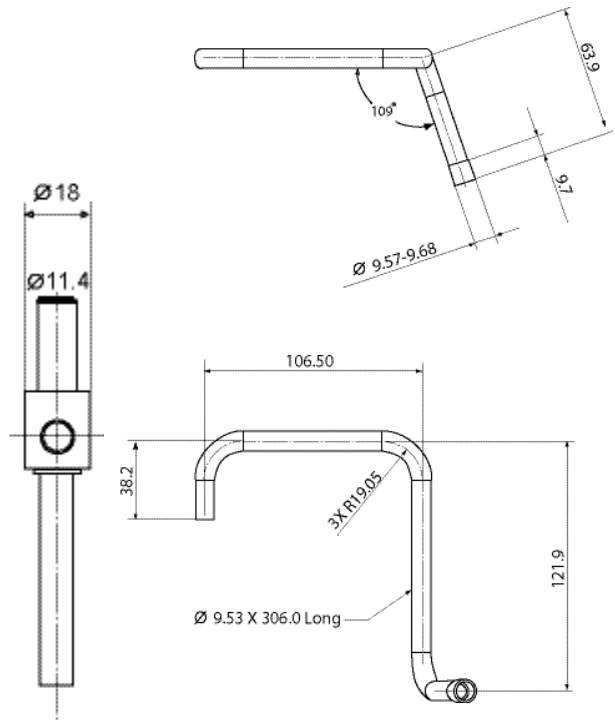

Figure 11: Control valve pipe connection

3.6 ZFD18KVE Copeland Scroll™ compressor with vapour injection

Copeland Vapour Injection Scroll™ compressors are equipped with a vapour injection connection for Economizer Operation. Economizing can be accomplished by utilising a subcooling circuit similar to the circuit shown in **figure 12**. This increases the refrigeration capacity and the system efficiency.

The line diagram shows a system configuration for the economizer cycle. A heat exchanger is used to provide additional subcooling to the refrigerant before it enters the evaporator. This subcooling process provides the increased capacity gain measured in the system.

The evaporated refrigerant through the HX is injected into the compressors and provides additional cooling at higher compression ratios.

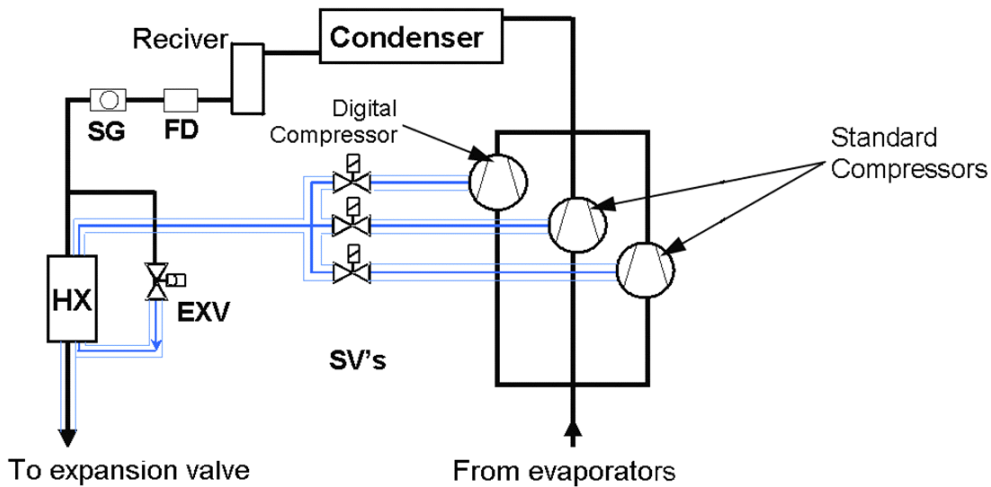

Figure 12: Vapour Injection Line Diagram

NOTE: For further information on Vapour Injection see the Technical Information “Vapour Injection Scroll Compressors for Refrigeration”.

3.7 Compressors in parallel

Copeland Digital Scroll™ compressors ZBD30KCE and ZBD45KCE are both capable of parallel operation if the single compressor cannot cover the required capacities and/or there are higher fluctuations in capacity demand. A gas and an oil equalization line must be fitted between both compressors at sight glass position. Copeland has conducted tests to prove the satisfactory operation of up to three compressors in parallel using a gas and oil equalizing tube.

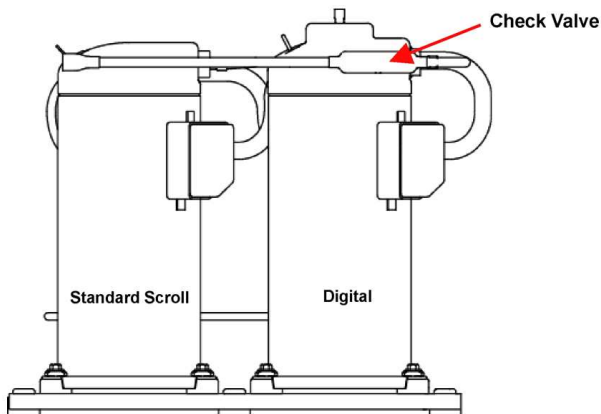

Figure 13: Parallel configuration

An OEM-system control device must be used to provide the signals for common operation, modulation as well as for single compressor operation. In general the architecture of such a

system controller runs the digital compressor continuously and cycles only the standard compressor if the capacity demand drops below, eg, 40% of the total capacity.

3.8 Discharge check valve

There is **no** discharge check valve at the discharge port of Copeland Digital Scroll™ compressors **ZBD30KCE, ZBD45KCE and ZFD18KVE** since the high side pressure is needed to support the operation of the unloader mechanism.

To avoid bypassing during the unloading process back to suction, a dynamic discharge valve is fitted internally on the discharge port of the fixed scroll. This discharge valve cannot be used with recycling pump down because it is not leak-proof during the off period.

NOTE: In tandem configurations, an external check valve for the Copeland Digital Scroll™ compressor must be fitted in the discharge line as shown in figure 13, at 10 to 15 cm from compressor outlet. This does not allow the discharge gas to bypass back to suction when the scroll is idle.

3.9 Oil separator

During any operating cycle of Copeland Digital Scroll™ compressors, there is a loaded state during which the compressor operates at full capacity. The velocity of gas during this loaded state is sufficient to return oil back to the compressor. Whenever the compressor runs unloaded there is no oil thrown into the system. Based on extensive tests, we do not strictly recommend the use of an oil separator, it is a matter of individual equipment design.

3.10 Accumulators



CAUTION

Inadequate lubrication! Bearing destruction! Minimise liquid refrigerant returning to the compressor. Too much refrigerant dilutes the oil. Liquid refrigerant can wash the oil off the bearings leading to overheating and bearing failure.

The use of accumulators is very dependent on the application. Due to Copeland Scroll's inherent ability to handle liquid refrigerant in flooded start and defrost cycle operation, no accumulator is required for durability below system charge of 4.5 kg (ZBD30/45KC*, ZFD18KVE) in a single compressor arrangement.

However, large volumes of liquid refrigerant that repeatedly flood back to the compressor during normal off cycles or excessive liquid refrigerant flood back during steady operation can dilute the oil. As a result, the bearings are inadequately lubricated and wear may occur.

The oil return orifice should be from 1 to 1.4 mm in diameter depending on compressor size and compressor flood back results.

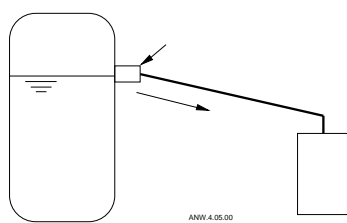

Figure 14: Suction Accumulator

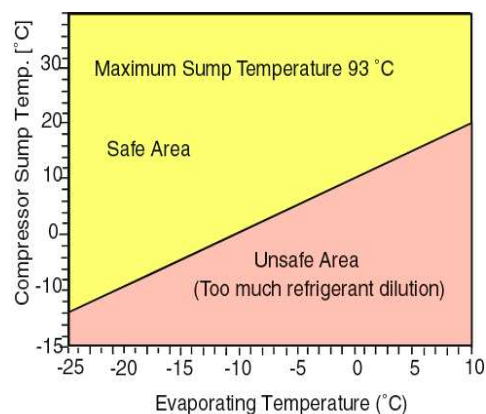

Figure 15: Bottom Shell Temperature

3.11 Screens



CAUTION

Screen blocking! Compressor breakdown! The use of screens finer than 0.6 mm x 0.6 mm mesh anywhere in the system is not recommended. Screens with a finer mesh can easily become plugged causing oil starvation to the compressor bearings. A compressor breakdown may be the consequence.

Field experience has shown that finer mesh screens used to protect thermal expansion valves, capillary tubes, or accumulators can become temporarily or permanently plugged with normal system debris and block the flow of either oil or refrigerant to the compressor. Such blockage can result in compressor failure.

3.12 Mufflers

External mufflers, normally applied to piston compressors in the past, may not be required for Copeland Scroll™ compressors.

Individual system tests should be performed to verify acceptability of sound performance. If adequate attenuation is not achieved, use a muffler with a larger cross-sectional area to inlet area ratio. A ratio of 20:1 to 30:1 is recommended.

A hollow shell muffler such as the Alco APD-1 will work quite well. The muffler should be located at minimum 15 to maximum 45 cm from the compressor for the most effective operation. The farther the muffler is placed from the compressor within these ranges, the more effective it is. Choose a muffler with a length of 4 to 10-15 cm.

3.13 Reversing valves

Since Copeland Scroll™ compressors have very high volumetric efficiency, their displacements are lower than those of equivalent capacity reciprocating compressors. As a result, Copeland recommends that the capacity rating on reversing valves be no more than 1.5 to 2 times the nominal capacity of the compressor in order to ensure proper operation of the reversing valve under all operating conditions.

The reversing valve solenoid should be wired so that the valve does not reverse when the system is shut off by the operating thermostat in the heating or cooling mode. If the valve is allowed to reverse at system shut off, suction and discharge pressures are reversed to the compressor. This results in a condition of system pressures equalising through the compressor which can cause the compressor to slowly rotate until the pressures equalise. This condition does not affect compressor durability but can cause unexpected sound after the compressor is turned off.

3.14 Suction line noise and vibration

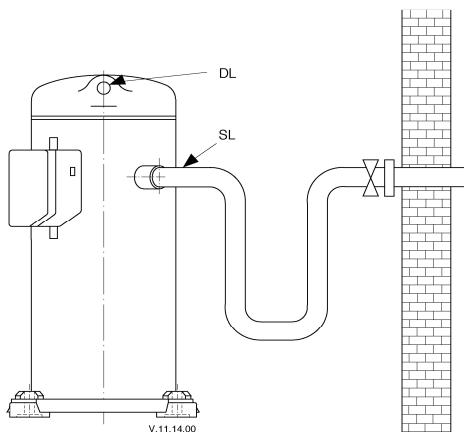

Figure 16: Suction Tube Design

Copeland Scroll™ compressors inherently have low sound and vibration characteristics. However in some respects the sound and vibration characteristics differ from reciprocating compressors and in rare instances could result in unexpected sound generation. One difference is that the vibration characteristic of the Scroll compressor, although low, includes two very close frequencies, one of which is normally isolated from the shell by the suspension of an internally-suspended compressor. These frequencies, which are present in all compressors, may result in a low-level "beat" frequency that can be detected as noise coming along the suction line into the building under some conditions. Elimination of the beat can be achieved by attenuating either of the contributing

frequencies. This is easily done by using one of the common combinations of recommended design configurations. The Scroll compressor makes both a rocking and twisting motion and enough flexibility must be provided in the line to prevent vibration transmission into any lines attached to the unit. In a split system, the most important goal is to ensure minimal vibration in all directions at the service valve to avoid transmitting vibrations to the structure to which the lines are fastened.

A second difference of the Copeland Scroll™ compressor is that under some conditions the normal rotational starting motion of the compressor can transmit an "impact" noise along the suction line. This may be particularly pronounced in three-phase models due to their inherently higher starting torque. This phenomenon, like the one described previously, also results from the lack of internal suspension and can be easily avoided by using standard suction line isolation techniques as described below.

The sound phenomena described above are not usually associated with reversible air conditioning / heat pump systems because of the isolation and attenuation provided by the reversing valve and tubing bends.

Recommended configuration

- Tubing configuration: small shock loop
- Service valve: "angled valve" fastened to unit / wall
- Suction muffler: not required

Alternative configuration

- Tubing configuration: small shock loop
- Service valve: "straight through" valve fastened to unit / wall
- Suction muffler: may be required (acts as dampening mass)

4 Electrical connection

4.1 General recommendations

The compressor terminal box has a wiring diagram on the inside of its cover. Before connecting the compressor, ensure the supply voltage, the phases and the frequency match the nameplate data.

4.2 Electrical installation

Motor insulation material class is "B" for models ZBD30KC*, ZBD45KC* and ZFD18KVE according to IEC 34-18-1 and EN 0530.

The orientation of the electrical connections on the Copeland Scroll™ compressors is shown in **figure 17**.

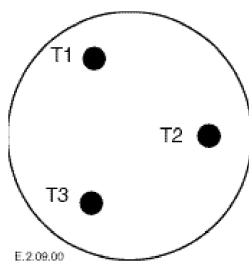

Figure 17: Motor terminal connections

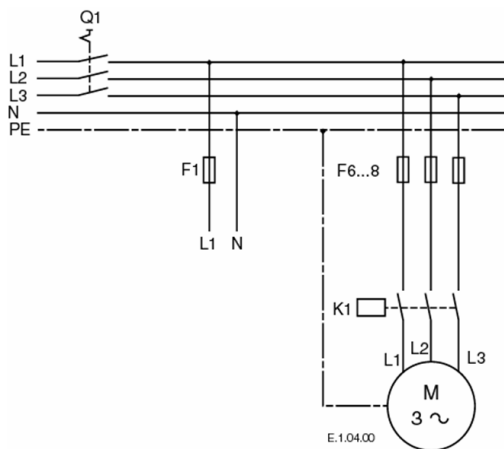

Figure 18: Power Circuit Three-Phase

4.2.1 Terminal box

The terminal box is IP21 for all models without electronic motor protection, eg, TF*.

4.2.2 Motor winding

The ZBD and ZFD Scroll compressors are offered only as three-phase induction motors. All three-phase motors are connected in star.

4.2.3 Protection devices

Independently from the internal motor protection, fuses must be installed before the compressor. Selection of fuses has to be carried out according to VDE 0635, DIN 57635, IEC 269-1 or EN 60-269-1.

4.2.4 Crankcase heaters



IMPORTANT

Oil dilution! Bearing malfunction! Turn the crankcase heater on 12 hours before starting the compressor.

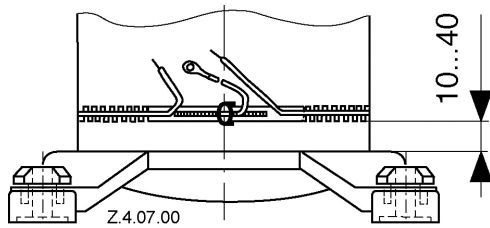

Figure 19: Crankcase Heater Location

Practically, for a multi evaporator system, system charge will be much higher than for standard single evaporator systems. In order to prevent flooded start, we strongly recommend to use a crankcase heater for all Copeland Digital Scroll™ applications. The crankcase heater should be wired in such a way that it is turned on whenever the compressor is switched off.

The crankcase heater must be turned on at minimum of 12 hours prior to starting the compressor and must remain energised during the compressor off cycle.

4.3 Pressure control

4.3.1 High-pressure control

A high-pressure control with a maximum cut out setting of 28 bar(g) is recommended.

The high-pressure control should have a manual reset feature for the highest level of system protection.

4.3.2 Low-pressure control



IMPORTANT!

Loss of system charge! Bearing malfunction! A low-pressure control is highly recommended for loss of charge protection. Do not bridge or by-pass the low-pressure cut out.

Even though these compressors have an internal discharge temperature sensor, loss of system charge etc. will result in overheating and recycling of the motor protector. Prolonged operation in this manner could result in oil pump out and eventual bearing failure.

A cut-out setting not lower than 0.3 bar(g) is recommended for ZBD and ZFD compressors using R404A and 1 bar(g) for ZBD compressors using R22.

An alternative is to keep the low-pressure control in the suction line and provide a 60-second maximum low-pressure time delay that ignores a signal from the low-pressure control and allows the compressor to continue operating.

The low-pressure cut-out, if installed in the suction line to the compressor, can provide additional protection against a EXV failed in the closed position, outdoor fan failure in heating, a closed liquid line or suction line service valve, or a blocked liquid line screen, filter, orifice, or EXV. All of these conditions may starve the compressor for refrigerant and may result in compressor failure.

The low-pressure cut-out should have a manual reset feature for the highest level of system protection.

4.3.3 IPR valve (Internal Pressure Relief valve)

The internal pressure relief valves for models ZBD30KCE, ZBD45KCE and ZFD18KVE are located between the high and the low sides of the compressor. They are designed to open when the discharge-to-suction differential pressure exceeds 26-31 bar. When the valve opens, high pressure is routed back into the suction area of the compressor.

4.4 Discharge temperature protection

These compressors come with a discharge temperature sensor (NTC thermistor) that is embedded in the side of the top cap of the compressor. This thermistor should be connected to the protection module of the Alco Digital Scroll Controller.

If an Alco Controller is not being used, a Discharge Line Thermostat (DLT) must be used for discharge temperature protection, placed on the discharge line 10 to 15 cm from the compressor discharge outlet.

The resistance curve for the NTC thermistor is provided in **table 3** hereunder:

Temperature (°C)	Resistance (kOhm)	Temperature (°C)	Resistance (kOhm)
-40	2,889.60	75	12.73
-35	2,087.22	80	10.79
-30	1,522.20	85	9.20
-25	1,121.44	90	7.87
-20	834.72	95	6.77
-15	627.28	100	5.85
-10	475.74	105	5.09
-5	363.99	110	4.45
0	280.82	115	3.87
5	218.41	120	3.35
10	171.17	125	2.92
15	135.14	130	2.58
20	107.44	135	2.28
25	86.00	140	2.02
30	69.28	145	1.80
35	56.16	150	1.59
40	45.81	155	1.39
45	37.58	160	1.25
50	30.99	165	1.12
55	25.68	170	1.01
60	21.40	175	0.92
65	17.91	180	0.83
70	15.07		

Table 3: Copeland Digital Scroll™ thermistor temperature / resistance values

4.5 High-potential testing



WARNING

Conductor cables! Electrical shock! Shut off power supply before high-potential testing.



CAUTION

Internal arcing! Motor destruction! Do not carry out high-voltage or insulation tests if the compressor housing is under vacuum.

Copeland subjects all Scroll compressors to a high-voltage test after final assembly. Each motor phase winding is tested according to EN 0530. Since high-voltage tests lead to premature aging of the winding insulation additional tests of that nature are not recommended.

If it has to be done for any reason, disconnect all electronic devices (fan speed control, PCB etc.) prior to testing. The test voltage of 1000 V plus twice the nominal voltage is applied for 1 to 4 seconds between motor winding (each one of the phases) and the compressor shell. The maximum leak current limit is approximately 10 mA. Repeated tests have to be performed at lower voltages.

5 Starting up & operation



WARNING

Diesel effect! Compressor destruction! The mixture of air and oil at high temperature can lead to an explosion. Avoid operating with air.



IMPORTANT

Oil dilution! Bearing malfunction! Turn the crankcase heater on 12 hours before starting the compressor.

5.1 Strength pressure test

The compressor has been strength-tested in the factory. It is not necessary for the customer to strength- or leak-test the compressor again although the compressor will normally be exposed to the testing made as part of system testing.

5.2 Tightness/pressure test



CAUTION

Consider personal safety requirements and refer to test pressures prior to test.



CAUTION

System contamination! Bearing malfunction! Use only dry nitrogen or dried air for pressure testing.



WARNING

System explosion! Personal injuries! DO NOT USE other industrial gases.

If using dry air do not include the compressor in the pressure test – isolate it first. Never add refrigerant to the test gas (as leak indicator).

5.3 Preliminary checks – Pre-starting



WARNING

Vacuum operation! Compressor damage!

Discuss details of the installation with the installer. If possible, obtain drawings, wiring diagrams, etc.

It is ideal to use a check-list but always check the following:

- Visual check of the electrics, wiring, fuses etc.
- Visual check of the plant for leaks, loose fittings such as TXV bulbs etc.
- Compressor oil level
- Calibration of HP & LP switches and any pressure actuated valves
- Setting and operation of all safety features and protection devices
- All valves in the correct running position
- Pressure and compound gauges fitted
- Correctly charged with refrigerant
- Compressor electrical isolator location & position

5.4 Pressure fluctuations

During the normal operation of the modulated scroll, there is a fluctuation in the suction and the discharge pressure. This fluctuation will be in the range of 2 to 3.5 bar. During the unloaded state, discharge pressure will start to drop and suction pressure will start to rise. This is normal. This pressure fluctuation has no effect on the reliability of any system components.

5.5 Charging procedure

Do not operate compressor without enough system charge to maintain at least 0.3 bar(g) suction pressure.

Do not operate with a restricted suction.

Do not operate with the low-pressure cut-out bridged.

Allowing pressure to drop below 0.3(g) bar for more than a few seconds may overheat scrolls and cause early drive bearing damage.

Do not use compressor to test opening set point of high-pressure cut-out.

Bearings are susceptible to damage before they have had several hours of normal running in.

The majority of the charge should be placed in the high side of the system to prevent bearing washout during first time start on the assembly line.

5.6 Rotation direction

Copeland Scroll™ compressors, like several other types of compressors, will only compress in one rotational direction. Three-phase compressors will rotate in either direction depending upon phasing of the power. Since there is a 50-50 chance of connecting power in such a way as to cause rotation in the reverse direction, **it is important to include notices and instructions in appropriate locations on the equipment to ensure proper rotation direction is achieved when the system is installed and operated.**

Observing that suction pressure drops and discharge pressure rises when the compressor is energized allows verification of proper rotation direction. There is no negative impact on durability caused by operating three-phase Copeland Scroll™ compressors in the reversed direction for a short period of time (under one hour) but oil may be lost. Oil loss can be prevented during reverse rotation if the tubing is routed at least 15 cm above the compressor. After several minutes of operation in reverse, the compressor's protection system will trip due to high motor temperature. The operator will notice a lack of cooling. However, if allowed to repeatedly restart and run in reverse without correcting the situation, the compressor will be permanently damaged.

All three-phase Scroll compressors are identically wired internally. Therefore, once the correct phasing is determined for a specific system or installation, connecting properly phased power leads to the identified compressor terminals will ensure proper rotation direction.

5.7 Starting

During the very brief start-up, a clicking sound is audible, resulting from initial contacting of the spirals and is normal. Due to the design of the Copeland Scroll™, the internal compression components always start unloaded even if system pressures are not balanced. In addition, since internal compressor pressures are always balanced at start-up, low-voltage starting characteristics are excellent for Copeland Scroll™ compressors.

5.8 Deep vacuum operation



IMPORTANT

Vacuum operation causes damage to the drive bearing of the scrolls. Copeland Scroll™ compressors are able to pull vacuum very quickly and this should be avoided.

Copeland Scroll™ compressors should never be used to evacuate a refrigeration or air-conditioning system. The compressor can be used to pump down refrigerant in a unit as long as the pressures remain within the operating envelope. Prolonged operation at low suction pressures will result in overheating of the scrolls and permanent damage to the compressor drive bearing.

5.9 Shell temperature

The top shell and discharge line can briefly but repeatedly reach temperatures above 177°C if the compressor cycles on its internal protection devices. This only happens under rare circumstances and can be caused by the failure of system components such as the condenser or evaporator fan or loss of charge and depends upon the type of expansion control. Care must be taken to ensure that wiring or other materials that could be damaged by these temperatures do not come in contact with the shell.

5.10 Minimum run time

There is no set answer to how often Copeland Digital Scroll™ compressors can be started and stopped in an hour, since it is highly dependent on system configuration. The compressors should run fully loaded after each start for long enough to ensure oil return. There is no minimum off time because Scroll compressors start unloaded, even if the system has unbalanced pressures.

The most critical consideration is the minimum run time required to return oil to the compressor after start-up. To establish the minimum run time obtain a sample compressor equipped with a sight tube (available from Copeland) and install it in a system with the longest connecting lines that are approved for the system. The minimum on time becomes the time required for oil lost during compressor start-up to return to the compressor sump and restore a minimal oil level that will ensure oil pick-up through the crankshaft. Cycling the compressor for a shorter period than this, for instance to maintain very tight temperature control, will result in progressive loss of oil and damage to the compressor.

5.11 Power factor

During the loaded state, when the Copeland Digital Scroll™ compressor operates at full capacity, the power factor is almost the same as with a standard scroll. However, when the scrolls are unloaded, the power factor is lower.

6 Maintenance & repair

6.1 Exchanging the refrigerant

- Qualified Refrigerants and oils are given in section 2.4.1.

It is not necessary to replace the refrigerant with new unless contamination due to an error such as topping up the system with an incorrect refrigerant is suspected. To verify correct refrigerant composition, a sample can be taken for chemical analysis. A check can be made during shut down by comparing the refrigerant temperature and pressure using precision measurements at a location in the system where liquid and vapour phases are present and when the temperatures have stabilised.

In the event that the refrigerant needs replacing, the charge should be recovered using a suitable recovery unit.

6.2 Rotalock valves

Rotalock valves should be periodically re-torqued to ensure that leak tightness is maintained.

6.3 Replacing a compressor



CAUTION

Inadequate lubrication! Bearing destruction! Exchange the accumulator after replacing a compressor with a burned out motor. The accumulator oil return orifice or screen may be plugged with debris or may become plugged. This will result in starvation of oil to the new compressor and a second failure.

6.3.1 Compressor replacement

In the case of a motor burnout, the majority of contaminated oil will be removed with the compressor. The rest of the oil is cleaned through the use of suction and liquid line filter driers. A 100% activated alumina suction line filter drier is recommended but must be removed after 72 hours. **It is highly recommended that the suction accumulator be replaced if the system contains one.** This is because the accumulator oil return orifice or screen may be plugged with debris or may become plugged shortly after a compressor failure. This will result in starvation of oil to the replacement compressor and a second failure. When a single compressor or tandem is exchanged in the field, it is possible that a major portion of the oil may still be in the system. While this may not affect the reliability of the replacement compressor, the extra oil will add to rotor drag and increase power usage.

6.3.2 Start-up of a new or replacement compressor

Rapid charging only on the suction side of a scroll-equipped system or condensing unit can occasionally result in a temporary no start condition for the compressor. The reason for this is that, if the flanks of the compressor happen to be in a sealed position, rapid pressurisation of the low side without opposing high-side pressure can cause the scrolls to seal axially. As a result, until the pressures eventually equalise, the scrolls can be held tightly together preventing rotation. The best way to avoid this situation is to charge on both the high and low side simultaneously at a rate which does not result in axial loading of the scrolls.

A minimum suction pressure of 1.75 bar must be maintained during charging. Allowing pressure to drop below 0.3 bar for more than a few seconds may overheat scrolls and cause early drive bearing damage. Never install a system in the field and leave it unattended when it has no charge, a holding charge, or with the service valves closed without securely electrically locking out the system. This will prevent unauthorised personnel from accidentally operating the system and potentially ruining the compressor by operating with no refrigerant flow. **Do not start the compressor while the system is in a deep vacuum.** Internal arcing may occur when a scroll compressor is started in a vacuum causing burnout of the internal lead connections.

6.4 Lubrication and oil removal



WARNING

Chemical reaction! Compressor destruction! Do not mix up ester oils with mineral oil and/or alkyl benzene when used with chlorine-free (HFC) refrigerants.

Chlorine free refrigerants like R404A use polyolester oil, identified as POE, along with the charge quantity on the nameplate. These models have an “E” in the model nomenclature. An example would be the ZBD30KCE-TFD compressor. Use only Copeland approved oils for refilling or oil exchange. A complete recharge should be 118 ml less than the nameplate value.

One disadvantage of POE is that it is far more hygroscopic than mineral oil (see **Fig. 20**). Only brief exposure to ambient air is needed for POE to absorb sufficient moisture to make it unacceptable for use in a refrigeration system. Since POE holds moisture more readily than mineral oil it is more difficult to remove it through the use of vacuum. Compressors supplied by Copeland contain oil with low moisture content, and it may rise during the system assembling process. Therefore, it is recommended that a properly sized filter drier is installed in all POE systems. This will maintain the moisture level in the oil to less than 50 ppm. If oil is charged into a system, it is recommended to use POE with a moisture content no higher than 50 ppm.

If the moisture content of the oil in a refrigeration system reaches unacceptably high levels, corrosion and copper plating may occur. The system should be evacuated down to 0.3 mbar or lower. If there is uncertainty as to the moisture content in the system, an oil sample should be taken and tested for moisture. Sight glass/moisture indicators currently available can be used with the HFC refrigerants and lubricants; however, the moisture indicator will just show the moisture content of the refrigerant. The actual moisture level of POE would be higher than the sight glass specifies. This is due to the high hygroscopicity of the POE oil. To determine the actual moisture content of the lubricant, samples would have to be taken from the system and analysed.

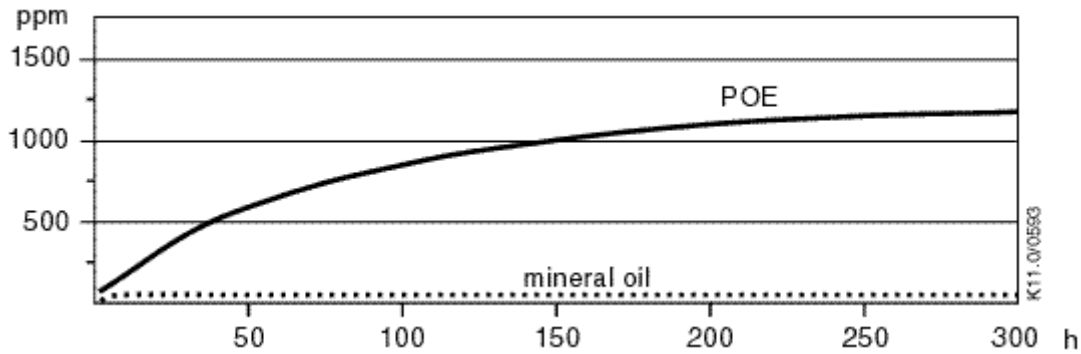

Figure 20: Absorption of moisture in ester oil in comparison to mineral oil in ppm by weight at 25°C and 50% relative humidity (h=hours)

6.5 Unbrazing system components



WARNING

Explosive flame! Burning! Oil-refrigerant mixtures are highly flammable. Remove all refrigerant before opening the system. Avoid working with an unshielded flame in a refrigerant charged system.

Before opening up a system it is important to remove all refrigerant from both the high and low sides of the system. If the refrigerant charge is removed from a scroll-equipped unit from the high side only, it is possible for the scrolls to seal, preventing pressure equalization through the compressor. This may leave the low side shell and suction line tubing pressurized. If a brazing torch is then applied to the low side while the low side shell and suction line contain pressure, the pressurized refrigerant and oil mixture could ignite when it escapes and contacts the brazing flame. To prevent this occurrence, it is important to check both the high and low sides with manifold gauges before unbrazing. Instructions should be provided in appropriate product literature and assembly (line repair) areas. If compressor removal is required, the compressor should be cut out of system rather than unbrazed.

6.6 Copeland Scroll™ functional check



IMPORTANT

A functional compressor test during which the suction service valve is closed to check how low the compressor will pull suction pressure is not a good indication of how well a compressor is performing. Such test must be avoided as it can damage a scroll compressor.

The following diagnostic procedure should be used to evaluate whether a Copeland Scroll™ compressor is functioning properly:

- Proper voltage to the unit should be verified.
- The normal checks of motor winding continuity and short to ground should be made to determine if the inherent overload motor protector has opened or if an internal motor short or ground fault has developed. If the protector has opened, the compressor must be allowed to cool sufficiently to allow it to reset.
- Proper indoor and outdoor fan / blower operation should be verified.
- With service gauges connected to suction and discharge pressure fittings, turn on the compressor. If suction pressure falls below normal levels the system is either low on charge or there is a flow blockage in the system.

7 Dismantling & disposal



Removing oil and refrigerant:

- Do not disperse in the environment.**
- Use the correct equipment and method of removal.**
- Dispose of oil and refrigerant properly.**
- Dispose of compressor properly.**

Benelux

Deltakade 7
NL-5928 PX Venlo
Tel. +31 (0) 77 324 0234
Fax +31 (0) 77 324 0235

UK & Ireland

17 Theale Lakes Business Park
GB-Theale, Nr Reading-Berkshire RG7 4GB
Tel: +44 (0)1189 83 8000
Fax: +44 (0)1189 83 8001

Asia/Pacific

10/F, Pioneer Building, 213 Wai Yip Street,
Kwun Tong, Kowloon - Hong Kong
Tel. +852 28 66 31 08
Fax +852 25 20 62 27

Deutschland/Österreich & Schweiz

Senefelder Straße 3
D-63477 Maintal
Tel. +49 (0)6109 6059 0
Fax +49 (0)6109 6059 40

Sweden/Denmark/Norway & Finland

Pascalstr. 65
D-52076 Aachen
Tel. +49 (0) 2408 929 127
Fax +49 (0) 2408 929 528

Latin America

7975 North West 154Th Street - Suite 300
Miami Lakes, FL, 33016 - USA
Tel. +1 305 818 8880
Fax +1 305 818 8888

France/Greece & Maghreb

8, Allee Du Moulin Berger
F-69130 Ecully
Tel. +33 (0)4 78668570
Fax +33 (0)4 78668571

Eastern Europe, Turkey & Iran

Pascalstr. 65
D-52076 Aachen
Tel. +49 (0) 2408 929 0
Fax +49 (0) 2408 929 525

Middle East & Africa

PO BOX 26382, R/A 8, FD-2
Jebel Ali, Dubai - UAE
Tel. +9714 883 2828
Fax +9714 883 2848

Italia

Via Ramazzotti, 26
I-21047 Saronno (va)
Tel. +39 02 961781
Fax +39 02 96178888

Poland

11A, Konstruktorska
PL-02-673 Warszawa
Tel. +48 225 458 9205
Fax +48 225 458 9255

España & Portugal

Diputacion, 238 AT.8
E-08007 Barcelona
Tel. +34 93 4123752
Fax +34 93 4124215

Russia & CIS

Letnikovskaya, 10, building 2, 5th floor
RUS-115114 Moscow
Tel. +7 495 981 9811
Fax +7 495 981 9816



Emerson Climate Technologies - European Headquarters - Pascalstr. 65 - D-52076 Aachen, Germany
Phone: +49 (0) 2408 929 0 - Fax: +49 (0) 2408 929 570 - Internet: www.eCopeland.com

The Emerson Climate Technologies logo is a trademark and service mark of Emerson Electric Co. Copeland Corporation is a subsidiary of Emerson Electric Co. Copeland is a registered trademark and Copeland Scroll is a trademark of Copeland Corporation. Information contained in this brochure is subject to change without notification. Логотип Emerson Climate Technologies является торговой и сервисной маркой компании Emerson Electric Co. Корпорация Copeland является дочерней компанией Emerson Electric Co. Copeland - зарегистрированный товарный знак, а Copeland Scroll - торговая марка корпорации Copeland. Приведенная в данной брошюре информация может быть изменена без уведомления.
© 2006 Copeland



EMERSON
Climate Technologies